

SPECIFICATION CONTROL DRAWING

THIS DRAWING CONTAINS INFORMATION PROPRIETARY TO RF INDUSTRIES, LTD. ANY UNAUTHORIZED USE OF THIS DRAWING IS EXPRESSLY PROHIBITED. ANY VIOLATION IS PUNISHABLE UNDER U.S. COPYRIGHT LAWS.

REV	DESCRIPTION	DWN	DATE	APPROVED
B	CHG BODY, PIN & DIELECTRIC TO STANDARDIZE WITH BNC	CZS	4/23/99	R. RICE
C	CHANGE DIELECTRIC & PIN CONFIGURATION	CZS	2/8/00	J. D. McR.
D	CHANGE DIMS THROUGHOUT	CZS	7/12/00	J. D. McR.
E	ADDED SOLDER ONLY NOTE & UPDATED SPECS	CZS	08/08/06	J. D. McR.

ALL DIMENSIONS ARE REFERENCE ONLY

000486

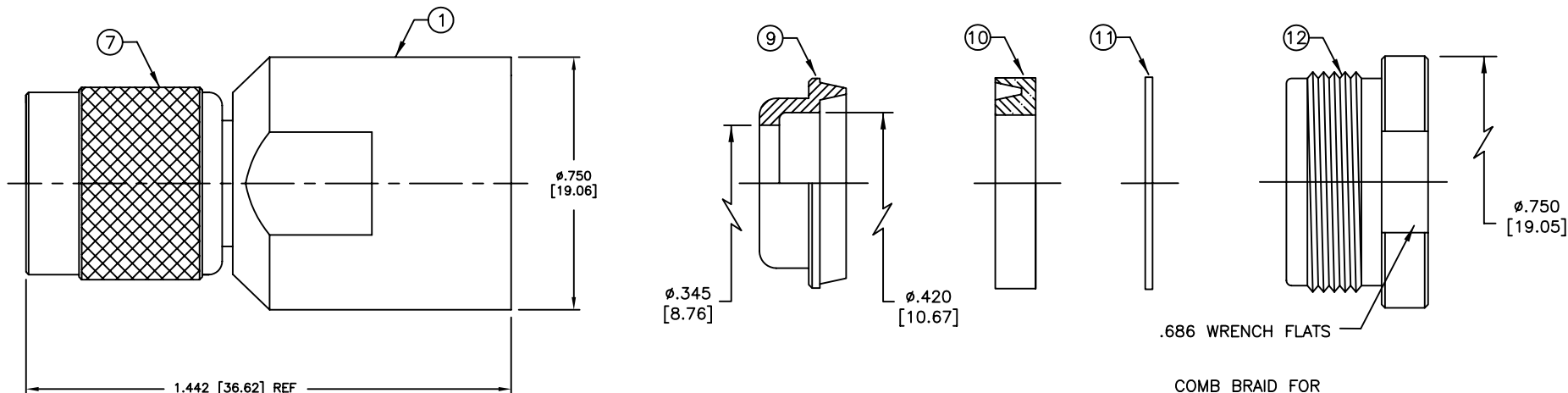

SPECIFICATIONS:

IMPEDANCE: 50 Ohms
 FREQUENCY RANGE: 0-7 GHz
 WORKING VOLTAGE: 500 V rms @ sea level
 INSULATION RESISTANCE: 5k M ohms min.
 TEMPERATURE RANGE: -65°C TO +85°C
 FOR BELDEN 8214, 9913, 9913F, 9914, RG-8/U TYPE,
 CAROL C1180, TIMES AA-5886 & LMR-400 CABLE

RECOMMENDED CRIMP DIE: .118" or .128"
"SOLDER ONLY" FOR RG-8/U TYPE CABLE

RECOMMENDED STRIPPING INSTRUCTIONS

ITEM	DESCRIPTION	QTY	MATERIAL	FINISH
12	BACK NUT	1	BRASS	SILVER
11	WASHER	1	BRASS	SILVER
10	GASKET	1	S.I. RUBBER	RED
9	CLAMP	1	BRASS	SILVER
8	PRESS FIT WASHER	1	BRASS	SILVER
7	SHELL	1	BRASS	SILVER
6	PRES FIT SLEEVE	1	BRASS	NONE
5	SPLIT LOCK WASHER	1	BRASS	SILVER
4	GASKET	1	S.I. RUBBER	RED
3	DIELECTRIC	1	TEFLON	NONE
2	PIN	1	BRASS	GOLD
1	BODY	1	BRASS	SILVER

DIMENSIONS ARE IN INCHES AND [MILLIMETERS]

UNLESS OTHERWISE NOTED TOLERANCES ARE:
DECIMALS DIAMETER

DRAWN C. ZUNIGA 08/08/06

CHECKED

ORJ DRAWN K. MAXWELL 6/3/96

APPROVALS DATE

RF

connectors

7610 MIRAMAR RD
 SAN DIEGO, CA 92126
 (858) 549-6340
 (858) 549-6345 FAX

DIVISION OF RF INDUSTRIES, LTD.

RFT-1201-SI

TNC MALE CLAMP

SIZE	CABLE GROUP	DWG NO.	REV
A	I	8646	E
SCALE: 2:1		CAD FILE D:\DETAIL1	SHEET 1 OF 1