

***** THIS DRAWING AND ITS CONTENTS ARE THE SOLE PROPERTY OF PRECISION CONNECTOR INC. AND ARE SUBJECT TO CHANGE WITHOUT NOTICE UNLESS OTHERWISE SPECIFIED *****

REV.	DESCRIPTION	DATE	BY	APPVD
A	INITIAL RELEASE	02/25/11	RDE	MJK

NOTES :

1. TNCA JACK INTERFACE PER MIL-STD-348, FIGURE 313-4.
2. MOUNTING HOLE AND BODY 'D' FLAT MEET MIL-PRF-39012/28G.

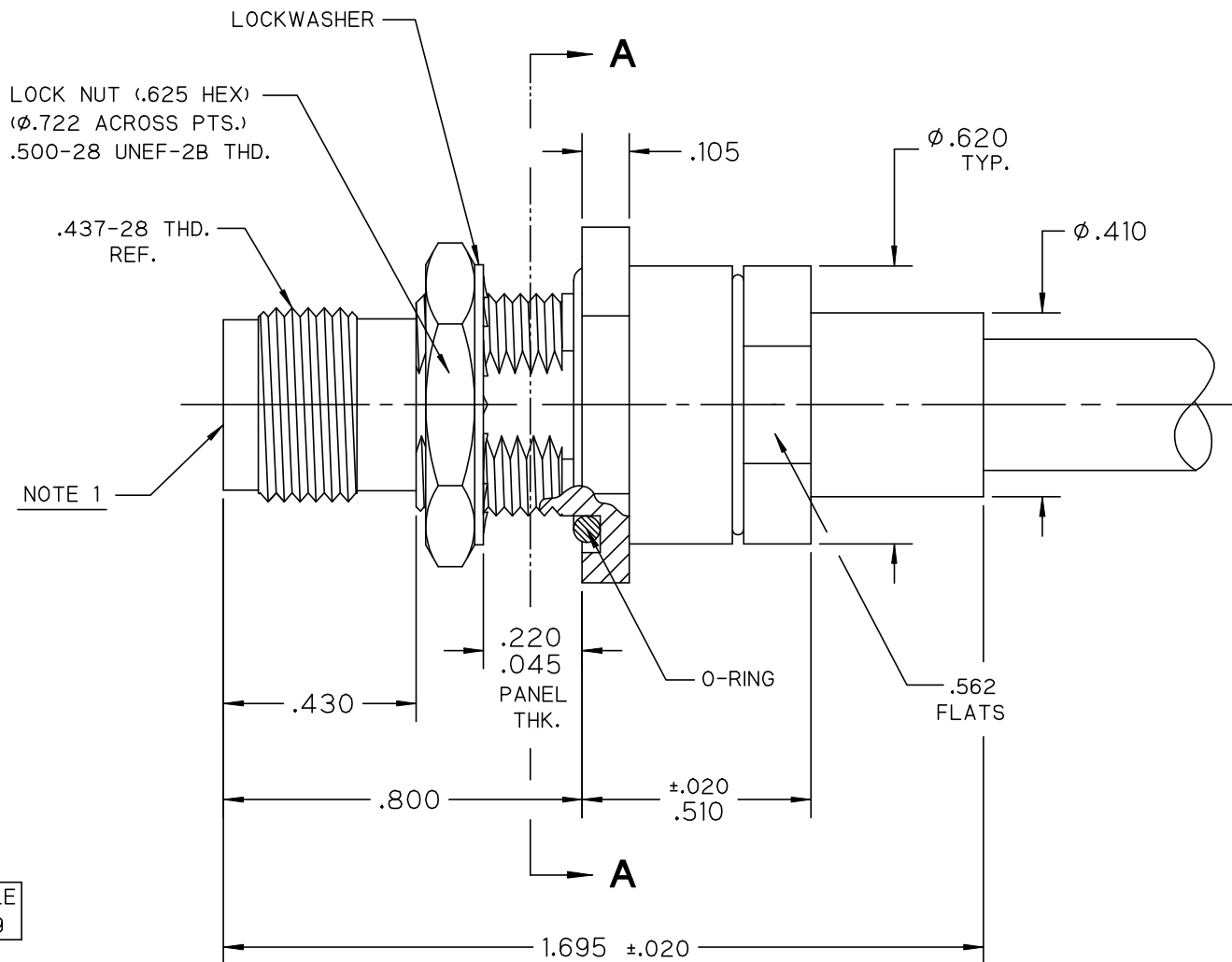
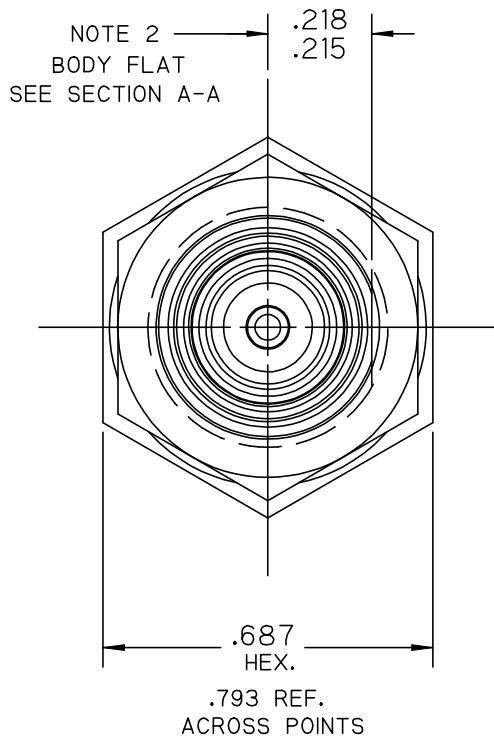

NOTE: DISTANCE FROM END OF CABLE CENTER COND. TO REF. PL. IS .359



Precision Connector, Inc.

TOLERANCES UNLESS OTHERWISE SPECIFIED		DRAWN BY: RDE		DESCRIPTION TNCA BULKHEAD JACK, SOLDER CLAMP FOR DYNAWAVE DF218 CABLE			
.XX	± .02	DATE: 02/25/11		CAGE CODE	SCALE	SHEET NO.	ASSEMBLY NUMBER
.XXX	± .005	4MJR5		5:2	1 OF 2	3536-0L	REV
.XXXX	± .0005						A
ANGLES	± 2°						

***** THIS DRAWING AND ITS CONTENTS ARE THE SOLE PROPERTY OF PRECISION CONNECTOR INC. AND ARE SUBJECT TO CHANGE WITHOUT NOTICE UNLESS OTHERWISE SPECIFIED *****

REV.	DESCRIPTION	DATE	BY	APPVD
A	INITIAL RELEASE	02/25/11	RDE	MJK

NOTES :

1.0 MATERIALS:

- 1.1 BODY, CLAMP NUT & LOCK NUT: STEEL, CORROSION RESISTANT PER ASTM-A582, UNS NO. S30300.
- 1.2 LOCKWASHER: STEEL, CORROSION RESISTANT PER ASTM-A313, UNS NO. S30200.
- 1.3 CENTER COND.: BERYLLIUM COPPER PER ASTM-B196, UNS C17300.
- 1.4 SOLDER FERRULE: BRASS PER ASTM-B16, UNS C36000.
- 1.5 INSULATOR: PTFE FLUOROCARBON PER ASTM-D1710.
- 1.6 O-RING(S): SILICONE RUBBER PER A-A-59588.
- 1.7 DIELECTRIC BEAD: POLYETHERIMIDE THERMOPLASTIC (ULTEM 1000) PER ASTM-D5205.

2.0 FINISHES:

- 2.1 BODY, LOCKWASHER, CLAMP NUT & LOCK NUT: PASSIVATE PER SAE-AMS-2700.
- 2.2 CENTER CONTACT & SOLDER FERRULE: GOLD PLATE PER ASTM-B488, 50 MICROINCHES MIN. THK. OVER ELECTROLYTIC NICKEL PLATE PER ASTM-B689, 50 MICROINCHES MIN. THK.
- 2.3 O-RING(S), INSULATOR & DIELECTRIC BEAD: NONE.

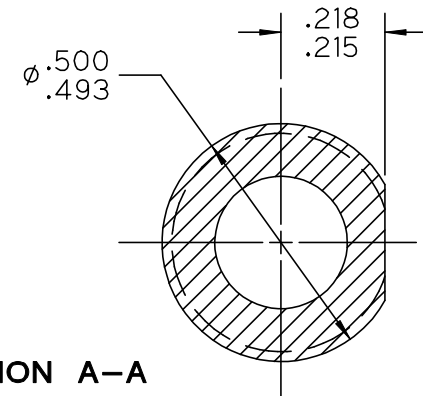

SECTION A-A

SINGLE BODY
"D" FLAT
(SECTION VIEW
PERP. TO AXIS)

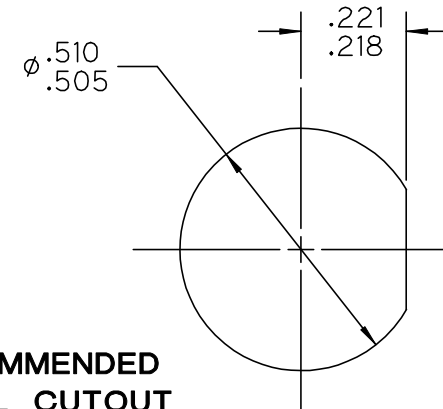

**RECOMMENDED
PANEL CUTOUT**



TOLERANCES UNLESS OTHERWISE SPECIFIED		DRAWN BY: RDE		DESCRIPTION TNCA BULKHEAD JACK, SOLDER CLAMP FOR DYNAWAVE DF218 CABLE				
.XX	± .02	DATE: 02/25/11		CAGE CODE	SCALE	SHEET NO.	ASSEMBLY NUMBER	REV
.XXX	± .005	4MJR5		5:2	2 OF 2	3536-0L	A	
.XXXX	± .0005							
ANGLES	± 2°							