

***** THIS DRAWING AND ITS CONTENTS ARE THE SOLE PROPERTY OF PRECISION CONNECTOR INC. AND ARE SUBJECT TO CHANGE WITHOUT NOTICE UNLESS OTHERWISE SPECIFIED *****

REV.	DESCRIPTION	DATE	BY	APPVD
A	INITIAL RELEASE	07/30/09	MJK	MJK

NOTE 4.0

Ø.032 +.004/-.000 LOCKWIRE
HOLES (3) PLACES 120° APART

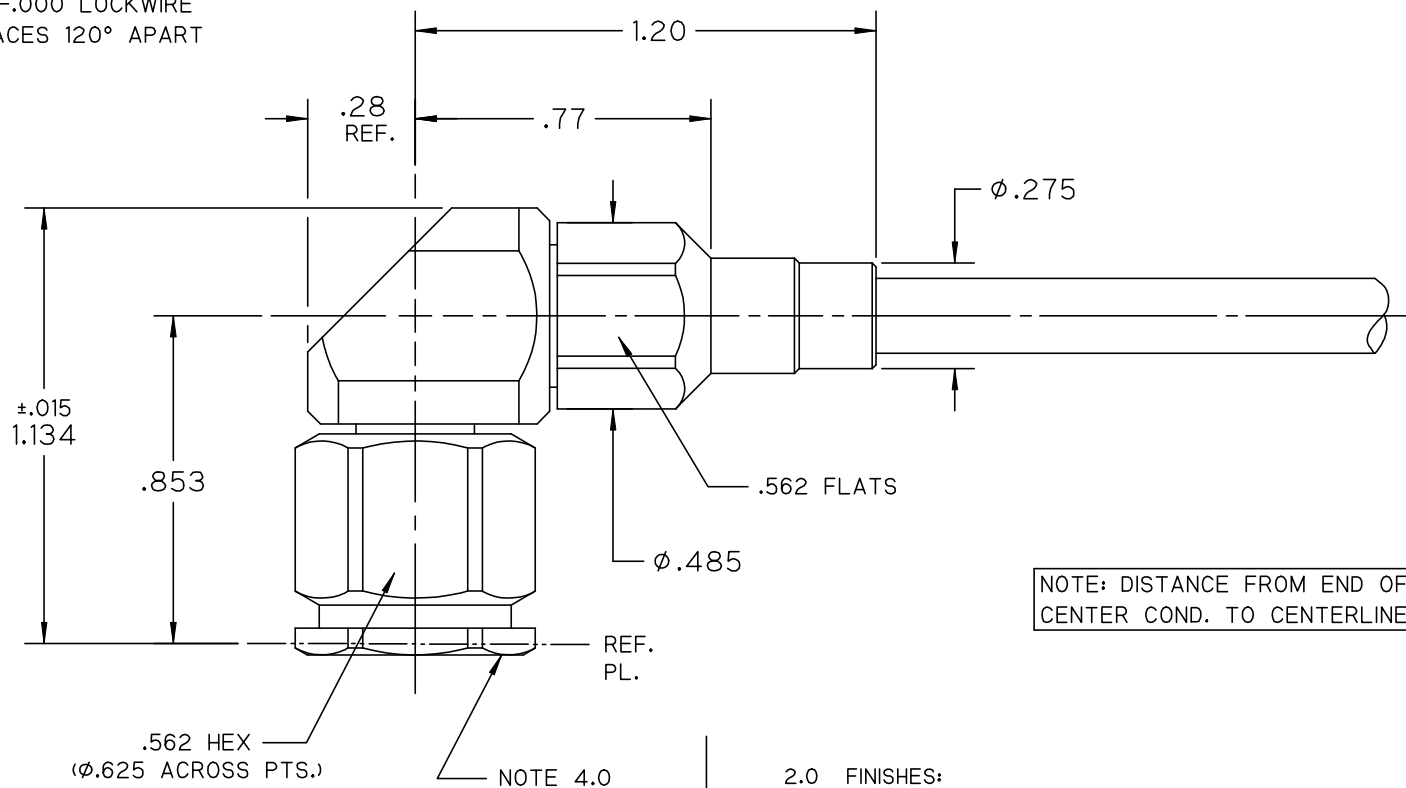

NOTE: DISTANCE FROM END OF CABLE CENTER COND. TO CENTERLINE IS .460

NOTES :

1.0 MATERIALS:

- 1.1 BODY, COUPLING & CLAMP NUTS: STEEL, CORROSION RESISTANT PER ASTM-A582, UNS NO. S30300.
- 1.2 CENTER COND.: BERYLLIUM COPPER PER ASTM-B196, UNS C17300.
- 1.3 SOLDER FERRULE: BRASS PER ASTM-B16, UNS C36000.
- 1.4 GASKET : SILICONE RUBBER PER A-A-59588.
- 1.5 INSULATOR(S): PTFE FLUOROCARBON PER ASTM-D1710.

2.0 FINISHES:

- 2.1 CENTER CONTACT & SOLDER FERRULE: GOLD PLATE PER ASTM-B488, 50 MICROINCHES MIN. THK. OVER ELECTROLYTIC NICKEL PLATE PER ASTM-B689 50 MICROINCHES MIN. THK.
 - 2.2 BODY, COUPLING & CLAMP NUTS: PASSIVATE PER SAE-AMS-2700.
 - 2.3 GASKET & DIELECTRICS: NONE.
- 3.0 INTERFACE MEETS TNCA PER MIL-STD-348, FIGURE 313-3.
(NOTE: ADDITIONAL Ø.267 X .0075 DP. C'BORE IS PROVIDED ON REFERENCE PLANE TO CLEAR JACK DIELECTRIC WHEN MATED TO STANDARD OR TEST GRADE TNC CONNECTORS).



TOLERANCES UNLESS OTHERWISE SPECIFIED		DRAWN BY: MJK		DESC.: TNCA, RT. ANGLE PLUG, SOLDER CLAMP FOR LL142 CABLE		
		DATE: 07/30/09				
.XX	± .02	CAGE CODE		SCALE	SHEET NO.	DRAWING NUMBER
.XXX	± .005	4MJR5		2:1	1 OF 1	3369-0L
.XXXX	± .0005					
ANGLES	± 2°					REV
						A