

THIS DRAWING CONTAINS INFORMATION PROPRIETARY TO RF INDUSTRIES,
 ANY UNAUTHORIZED USE OF THIS DRAWING IS EXPRESSLY PROHIBITED
 WITHOUT WRITTEN PERMISSION FROM RF INDUSTRIES.
 ANY VIOLATION IS PUNISHABLE UNDER U.S. COPYRIGHT LAWS.

ALL DIMENSIONS ARE REFERENCE ONLY

PART NO.

RFN-1005-3C1

REV	DESCRIPTION	DWN	DATE	APPROVED
A	ENGINEERING RELEASE	CZS	10/29/99	R. RICE
B	CHANGE FERRULE STUD, FORMAT, SPECS & DWG # (9254A)	CZS	8/23/01	JDMc

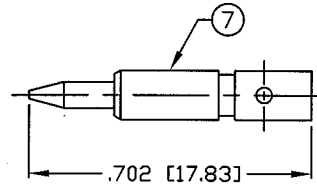
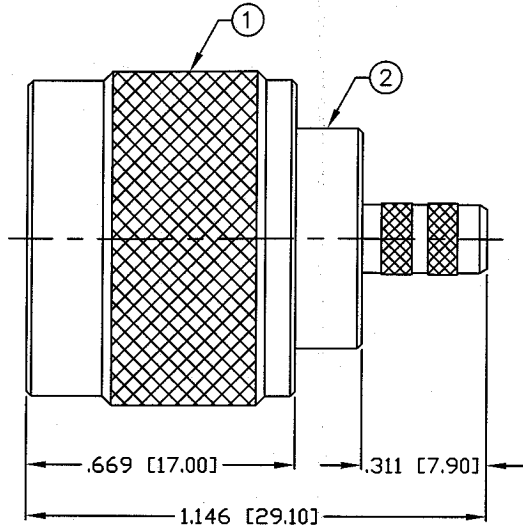

RECOMMENDED CRIMP DIE: .100

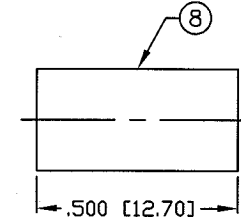

RECOMMENDED CRIMP DIE: .213

SPECIFICATIONS:

IMPEDANCE: 50 Ohms
 FREQUENCY RANGE: 0-11 GHz
 VSWR: 1.3 Max. @ 9 GHz
 INSERTION LOSS: .06 dB Max. x $\sqrt{f(\text{GHz})}$
 WORKING VOLTAGE: 1k V rms @ sea level
 TEMPERATURE RANGE: -65°C TO 165°C
 INSULATION RESISTANCE: 5k M Ohms min.
 (C1) FOR RG-55, 55A, 55B, 142, 142A, 142B, 223 & 400/U,
 ALPHA 9055, 9055B, 9223, BELDEN 8219, 83242, 84142, 9907

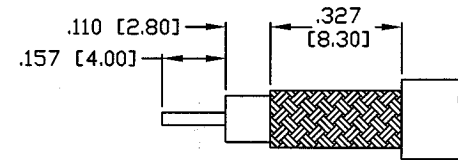

RECOMMENDED STRIPPING DIM'S

1	SHELL	1	BRASS	SILVER, 80μ"
2	BODY	1	BRASS	SILVER, 80μ"
3	INSULATOR	1	PTFE	----
4	GROUND RING	1	BRASS	SILVER, 80μ"
5	GASKET	1	SILICONE	----
6	RETAINING RING	1	SUS 304	----
7	PIN	1	BRASS	GOLD, 3μ"
8	FERRULE	1	BRASS	SILVER, 80μ"
9				
10				
11				
12				
13				
14				
#	DESCRIPTION	QTY	MATERIAL	FINISH

008974				
DRAWN	C. ZUNIGA	8/23/01		
CHECKED	JDM	8-11-01		
ORJ DRAWN	C. ZUNIGA	10/29/99		
APPROVALS	DATE			

UNLESS OTHERWISE SPECIFIED:
 1. REMOVE ALL BURRS
 2. BREAK ALL CORNERS & EDGES .005 R. MAX.
 3. CHAMFER 1ST & LAST THREADS 45°
 4. SURFACE ROUGHNESS 63 FINISH MIL-STD-10
 5. DIAMETERS ON COMMON CENTERS TO BE CONCENTRIC WITHIN .002 T.I.R.
 6. ALL DIMENSIONS ARE AFTER PLATING.

DIMENSIONS ARE IN INCHES AND [MILLIMETERS]
 UNLESS OTHERWISE NOTED TOLERANCES ARE:
 DECIMALS .xxx±.003 [.08] .xx±.005 [.13]
 DIAMETER .xxx±.001 [.03] .xx±.003 [.08]

RF connectors
 DIVISION OF RF INDUSTRIES, LTD.

7610 MIRAMAR RD
 SAN DIEGO, CA 92126
 (858) 549-6340
 (858) 549-6345 FAX

N PLUG, CRIMP

SIZE	CABLE GROUP	DWG NO.	REV
A	C1	RFN-1005-3C1	B
SCALE: NTS		CAD FILE OUTLINE	SHEET 1 OF 1