

SPECIFICATION CONTROL DRAWING

THIS DRAWING CONTAINS INFORMATION PROPRIETARY TO RF INDUSTRIES, LTD. ANY UNAUTHORIZED USE OF THIS DRAWING IS EXPRESSLY PROHIBITED. ANY VIOLATION IS PUNISHABLE UNDER U.S. COPYRIGHT LAWS.

REV	DESCRIPTION	DWN	DATE	APPROVED
A	ENGINEERING RELEASE	WMD	1/19/94	C. JONES
B	CHANGE DIELECTRICS & BODY ID \ ADD PRESS FIT WASHER	KMM	8/18/97	R. RICE
C	CHANGE CONTACT, PIN & DIELECTRIC DIMENSIONS	CZS	4/12/99	R. RICE
D	CHANGE FERRULE CONFIGURATION	CZS	12/8/99	R. RICE

000000

ALL DIMENSIONS ARE REFERENCE ONLY

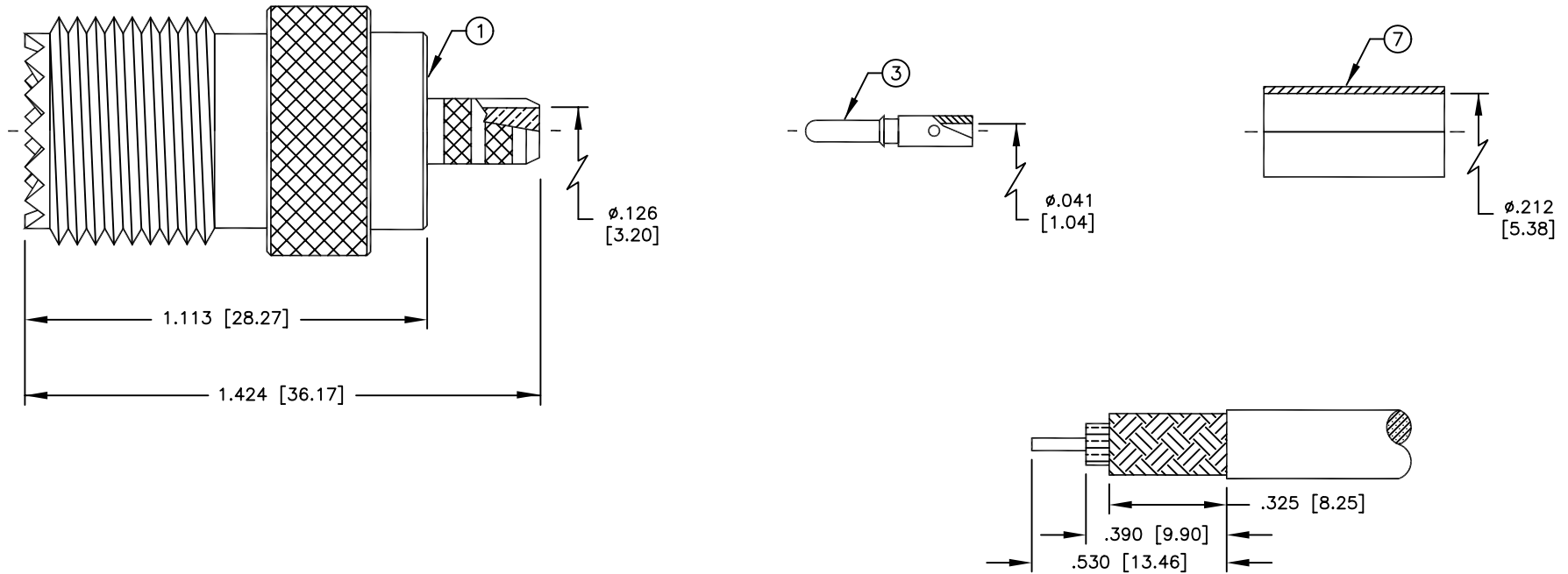

SUGGESTED STRIPPING INSTRUCTIONS

SUGGESTED CRIMP DIES: .068 & .213

SPECIFICATIONS:

IMPEDANCE: NON CONSTANT
 WORKING VOLTAGE: 500 VRMS @ SEA LEVEL
 FREQUENCY RANGE: 0-300 MHz
 FOR RG-58, 58A, 58C, 141, 141A, BELDEN 8240,
 8259, 8262, 9201, 9203, 9310, 9311 & COMM/SCOPE 0268

DIMENSIONS ARE IN INCHES
 AND [MILLIMETERS]

UNLESS OTHERWISE NOTED
 TOLERANCES ARE:

DECIMALS DIAMETER

DRAWN
 C. ZUNIGA 12/8/99

CHECKED

ORJ DRAWN
 W. DANIELS 1/19/94

APPROVALS DATE

RF connectors
 DIVISION OF RF INDUSTRIES, LTD.

7610 MIRAMAR RD
 SAN DIEGO, CA 92126
 (858) 549-6340
 (858) 549-6345 FAX

RFU-527-T

UHF FEMALE CRIMP

SIZE	CABLE GROUP	DWG NO.	REV
A	C	8294	D

SCALE: 2:1 CAD FILE 13ARC B SHEET 1 OF 1

ITEM	DESCRIPTION	QTY	MATERIAL	FINISH
7	CRIMP RING [FER-103]	1	BRASS	NICKEL
6	PRESS FIT WASHER	1	BRASS	NICKEL
5	DIELECTRIC	1	TEFLON	NONE
4	DIELECTRIC	1	TEFLON	NONE
3	REMOVABLE PIN	1	BRASS	SILVER
2	CONTACT	1	BRASS	SILVER
1	BODY	1	BRASS	NICKEL