

THIS DRAWING CONTAINS INFORMATION PROPRIETARY TO RF INDUSTRIES.  
 ANY UNAUTHORIZED USE OF THIS DRAWING IS EXPRESSLY PROHIBITED  
 WITHOUT WRITTEN PERMISSION FROM RF INDUSTRIES.  
 ANY VIOLATION IS PUNISHABLE UNDER U.S. COPYRIGHT LAWS.

ALL DIMENSIONS ARE REFERENCE ONLY

PART NO.

**RFU-507-STF1**

REV	DESCRIPTION	DWN	DATE	APPROVED
-	ENGINEERING RELEASE	CZS	2/6/01	JDMc

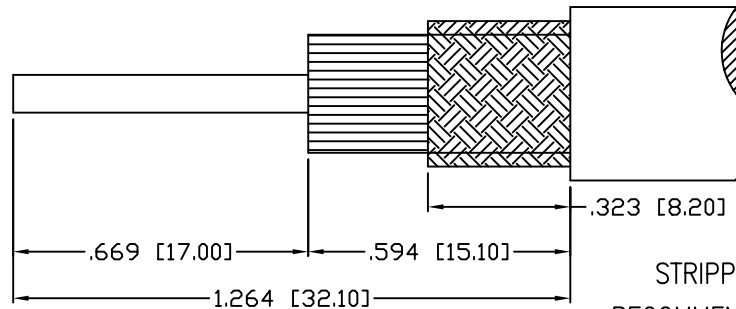
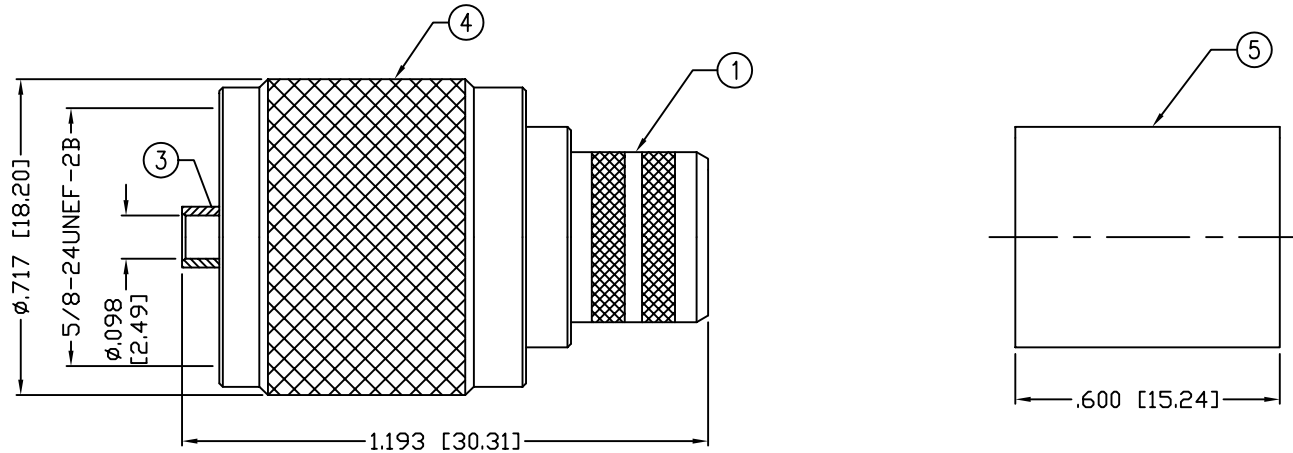

STRIPPING INSTRUCTIONS  
 RECOMMENDED CRIMP SIZE: .100 & .429

**SPECIFICATIONS:**

IMPEDANCE: 50 OHMS  
 FOR RG-9, 9A, 9B, 214 & 393/U, BELDEN 8242 & 8268 CABLE

1	BODY	1	BRASS	SILVER, 30 MICRO	000486	
2	INSULATOR	1	PTFE	---		
3	PIN	1	BRASS	SILVER, 30 MICRO		
4	SHELL	1	BRASS	SILVER, 30 MICRO		
5	FERRULE	1	BRASS	SILVER, 30 MICRO		
6						
7						
8						
9						
10					DRAWN	
11					C. ZUNIGA	
12					CHECKED	
13					2/6/01	
14					ORJ DRAWN	
					C. ZUNIGA	
					2/6/01	
#	DESCRIPTION	QTY	MATRL	FINISH	APPROVALS	DATE

UNLESS OTHERWISE SPECIFIED:  
 1. REMOVE ALL BURRS  
 2. BREAK ALL CORNERS & EDGES .005 R. MAX.  
 3. CHAMFER 1ST & LAST THREADS 45°  
 4. SURFACE ROUGHNESS 63 FINISH MIL-STD-10  
 5. DIAMETERS ON COMMON CENTERS TO BE CONCENTRIC WITHIN .002 T.I.R.  
 6. ALL DIMENSIONS ARE AFTER PLATING.

DIMENSIONS ARE IN INCHES AND [MILLIMETERS]  
 UNLESS OTHERWISE NOTED TOLERANCES ARE:  
 DECIMALS      DIAMETER  
 .XXX±.003 [.08]      .XXX±.001 [.03]  
 .XX±.005 [.13]      .XX±.003 [.08]

**RFconnectors**  
 DIVISION OF RF INDUSTRIES, LTD.

7610 MIRAMAR RD  
 SAN DIEGO, CA 92126  
 (858) 549-6340  
 (858) 549-6345 FAX

**UHF MALE CRIMP**

SIZE	CABLE GROUP	DWG NO.	REV
A	F1	RFU-507-STF1	-
SCALE:	NTS	CAD FILE	OUTLINE
			SHEET 1 OF 1