

THIS DRAWING CONTAINS INFORMATION PROPRIETARY TO RF INDUSTRIES.  
 ANY UNAUTHORIZED USE OF THIS DRAWING IS EXPRESSLY PROHIBITED  
 WITHOUT WRITTEN PERMISSION FROM RF INDUSTRIES.  
 ANY VIOLATION IS PUNISHABLE UNDER U.S. COPYRIGHT LAWS.

ALL DIMENSIONS ARE REFERENCE ONLY

PART NO.

**RFU-503**

REV	DESCRIPTION	DWN	DATE	APPROVED
A	ENGINEERING RELEASE	CJ	9/30/92	J. BENZ
B	CHANGE CLAMP DIMENSIONS ON PAGE 2 OF 2	PB	7/13/93	K.HARTMAN
C	CHANGE DIM THROUGHOUT / UPDATE DWG	CZS	8/30/99	R. RICE
D	CHANGE STRIPPING DIMENSIONS / CHANGE DWG # FROM 7734	CZS	08/12/00	JDMc

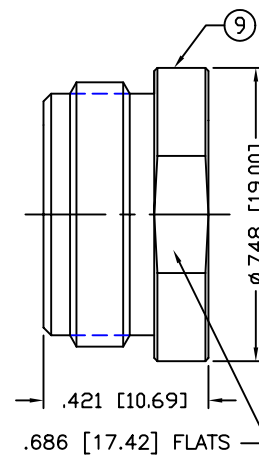
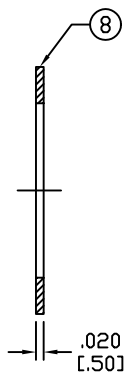
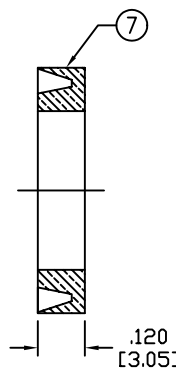
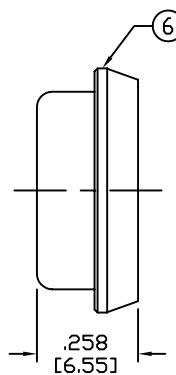
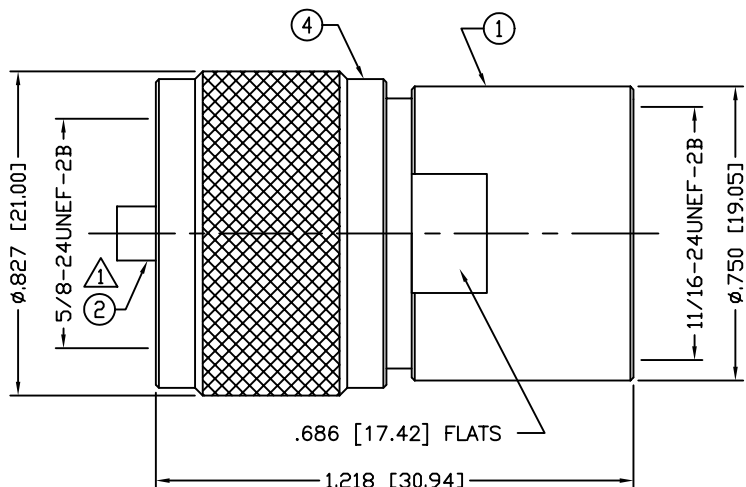

⚠ SOLDER ONLY IF USING STRANDED CENTER CONDUCTOR.  
 CRIMP OR SOLDER IF USING SOLID.

**SPECIFICATIONS:**

IMPEDANCE: NON CONSTANT  
 FREQUENCY RANGE: 0-300 MHz  
 WORKING VOLTAGE: 500 V rms max. @ sea level  
 (E) FOR RG-8, 8A, 213/U, ALPHA 9008, 9213, BELDEN 8267, 9251, 9880, 89880, INTERCOMP 4085, 22132, TIMES AA-4478  
 (F) FOR RG-9, 9A, 9B, 214 & 393/U, BELDEN 8242 & 8268 CABLE  
 (I) FOR BELDEN 8214, 9913, 9913F, 9914, RG-8/U TYPE, CAROL C1180, TIMES AA-5886 & LMR-400 CABLE

SCALE 2:1

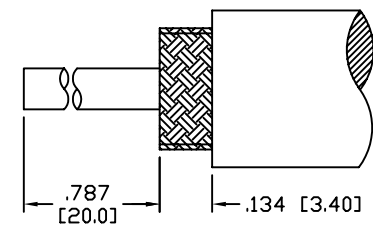
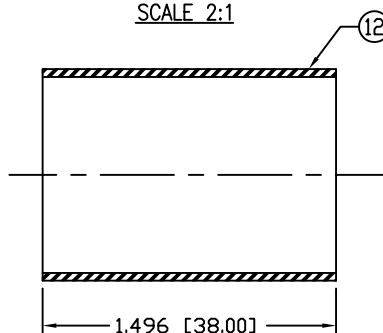

RECOMMENDED STRIPPING INSTRUCTIONS

1	BODY	1	BRASS	NICKEL, 80μ"	000486	
2	CONTACT	1	BRASS	SILVER, 5μ"		
3	INSULATOR	1	PTFE	---		
4	SHELL	1	BRASS	NICKEL, 80μ"		
5	PRESS WASHER	1	BRASS	NICKEL, 80μ"		
6	CLAMP	1	BRASS	NICKEL, 80μ"		
7	GASKET	1	RUBBER	---		
8	WASHER	1	BRASS	NICKEL, 80μ"		
9	BACK NUT	1	BRASS	NICKEL, 80μ"		
10	GASKET	1	RUBBER	---		
11	RETAINING RING	1	BRASS	NICKEL, 80μ"		
12	TUBING	1	HEAT SHRINK	---		
13						
14						
#	DESCRIPTION	QTY	MATERIAL	FINISH	APPROVALS	DATE

UNLESS OTHERWISE SPECIFIED:

DIMENSIONS ARE IN INCHES AND [MILLIMETERS]  
 UNLESS OTHERWISE NOTED TOLERANCES ARE:

DECIMALS      DIAMETER

**RFconnectors**  
 DIVISION OF RF INDUSTRIES, LTD.

7610 MIRAMAR RD  
 SAN DIEGO, CA 92126  
 (858) 549-6340  
 (858) 549-6345 FAX

**UHF PLUG, CLAMP**

WATERPROOF

SIZE	CABLE GROUP	DWG NO.	REV
A	E, F & I	RFU-503	D
SCALE:	NTS	CAD FILE	OUTLINE
		SHEET	1 OF 1