

**SPECIFICATIONS**

**ELECTRICAL**

FREQUENCY RANGE \_\_\_\_\_ DC - 25.6 GHz  
 VSWR \_\_\_\_\_ SEE TABLE  
 IMPEDANCE \_\_\_\_\_ 50 OHMS  
 TEMPERATURE RANGE \_\_\_\_\_ -65°C TO +125°C  
 POWER (AVG) \_\_\_\_\_ 1 WATTS  
 POWER DERATES LINEARLY FROM +45°C TO <10% @+125°C  
 POWER (PEAK) \_\_\_\_\_ 500 WATTS  
 (<5 μ SEC PW, <1% DUTY CYCLE)

**MECHANICAL**

INNER CONDUCTOR: \_\_\_\_\_ BERYLLIUM COPPER PER  
 ASTM B196 & B197.  
 OUTER CONDUCTOR: \_\_\_\_\_ STAINLESS STEEL, PER ASTM  
 A484 & A582, CLASS 303, COND. A.  
 DIELECTRIC: \_\_\_\_\_ TEFLON PER ASTM D1710.

**FINISH**

INNER CONDUCTOR: \_\_\_\_\_ GOLD PLATED PER MIL-PRF-39012.  
 HOUSING/COUPLING NUT FINISH PER SUFFIX (REPLACING -0X IN P/N)  
 -00 OUTER CONDUCTOR/NUT GOLD PLATED  
 -02 OUTER CONDUCTOR/NUT PASSIVATED SS  
 CONNECTOR INTERFACE COMPLIES WITH MIL-PRF-39012 AND MIL-STD-348  
 FOR SMA MATING CHARACTERISTICS.

**MARKING**

PART LOOKS LIKE PRODUCT IMAGE ABOVE.  
 PART MARKING ORIENTATION AND FORMAT AS SHOWN.  
 MARKING TO BE AS LARGE AS POSSIBLE, CLEAR AND READABLE.  
 YYWW EQUALS DATE CODE.  
 ADD "C" TO THE END OF PART NUMBER FOR CHAINED UNITS. (EXCLUDING  
 PARTS 2002-6105-0X AND 2002-6115-0X)

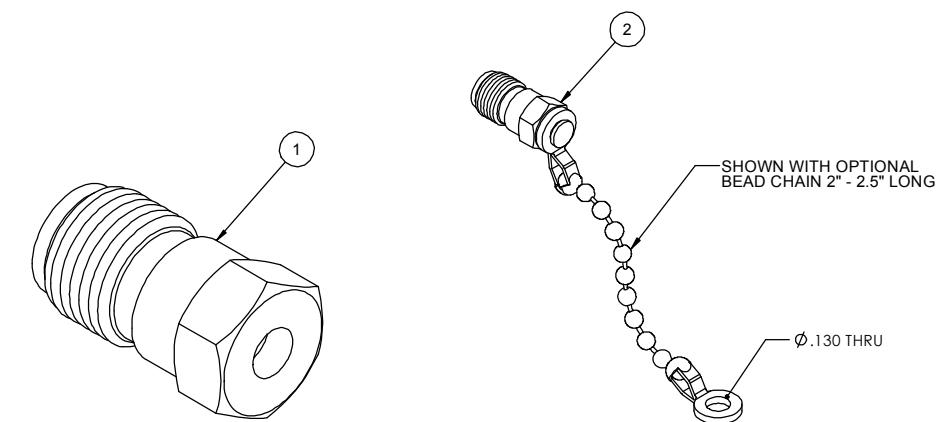

FREQUENCY (GHz)	VSWR DC-4 (GHz)	VSWR 4-12.4 (GHz)	VSWR 12.4-18 (GHz)	VSWR 18-26.5 (GHz)	PART NUMBER
DC-4	DC-1 1.05:1 2-4 1.10:1	-	-	-	2002-6151-0X
DC-12.4	1.05:1	1.05:1	-	-	2002-6116-0X
DC-18	1.05:1	1.10:1	1.25:1	-	2002-6144-0X
	1.05:1	1.15:1	1.15:1	-	2002-6105-0X *
	1.05:1	1.15:1	1.15:1	-	2002-6100-0X
	1.05:1	1.15:1	1.20:1	-	2002-6101-0X
	1.09:1	1.17:1	1.23:1	-	2002-6143-0X
	1.05:1	1.05:1	1.10:1	-	2002-6117-0X
	1.10:1	1.10:1	1.10:1	-	2002-6111-0X
	1.05:1	1.15:1	1.20:1	-	2002-6112-0X
DC-26.5	1.10:1	1.20:1	1.30:1	-	2002-6113-0X
	1.10:1	1.20:1	1.30:1	-	2002-6115-0X *
	1.05:1	1.10:1	1.20:1	1.30:1	2002-6110-0X
	1.05:1 + .007f (GHz)		1.05 @ DC TO 1.24 @ 26.5 GHz		2002-6119-0X

\* WITH 2" TO 2.5" MONEL BEAD CHAIN

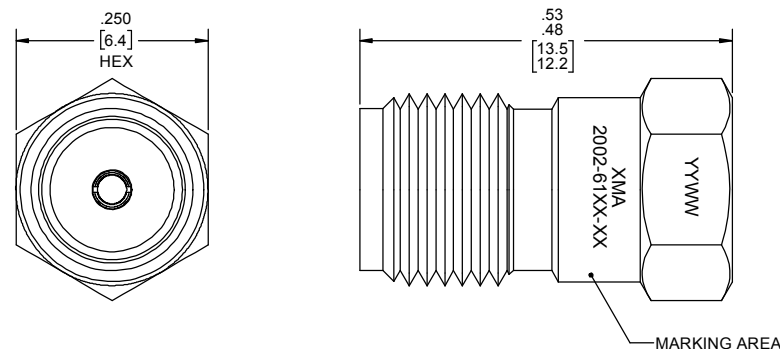

NO CHAIN	CHAIN	PART NUMBER	DESCRIPTION	ITEM NO.
		2002-61XX-0X	TERMINATION, SMA-f, DC-26.5 GHz	
1	-	TA-2002-6000-0XYYU	ASSEMBLY, TERMINATION, SMA-f, DC-26.5 GHz, UNMARKED	1
-	1	TA-2002-6000-0XYYUC	ASSEMBLY, TERMINATION, SMA-f, DC-26.5 GHz, CHAINED, UNMARKED	2

DRAWING PRACTICES PER ANSI Y14.5 DIMENSIONS ARE IN INCHES AND APPLY BEFORE/AFTER PROCESSING SURFACE ROUGHNESS IN INCHES: 63 FINISH: SEE NOTE MATERIAL: REMOVE ALL BURRS/SHARP W/BREAK / R OF .003" TO .0005" NOTE: THIS DRAWING INCORPORATES THIRD ANGLE PROJECTION. INTERPRET LAW ANSI Y14.5-1982	UNLESS OTHERWISE SPECIFIED TOLERANCES IN: DECIMALS INCH (MM) .X" .05" [1.27] .XX" .03" [.76] .XXX" .01" [.25]	DRAWN DATE MCCORMICK 6/25/15 CHECKED DATE MCCORMICK 6/25/15 ENG APPR. DATE T.KUHN 6/25/15	XMA Omni Spectra™ Phone: 603-222-2256 Fax: 603-222-2259 150 Dow Street, Manchester, NH 03103
THESE DRAWINGS AND SPECIFICATIONS ARE THE PROPERTY OF XMA CORP. OR OMNI SPECTRA AND SHALL NOT BE REPRODUCED, COPIED NOR USED IN WHOLE OR IN PART AS A BASIS FOR THE MANUFACTURE OR SALE OF OTHER ITEMS WITHOUT THE EXPRESS WRITTEN PERMISSION OF XMA CORP.			TERMINATION, SMA-f, DC-26.5 GHz, 1W
DO NOT SCALE PRINT		SIZE C CAGE CODE 3HT76 SCALE	DRAWING NUMBER 2002-61XX-0X REV G SHEET 1 OF 1

REVISIONS				
REV	DESCRIPTION	ECO #	DATE	APPROVED
E	ADDED MARKING/UPDATED FORMAT	15-203	6/25/15	T.KUHN
F	REVISED MARKING	15-257	9/1/15	T.KUHN
G	DELETED 2002-6118-0X FROM TABLE	17-113	7/20/17	T.KUHN