

4

3

2

1

SPECIFICATIONS

ELECTRICAL

FREQUENCY RANGE _____ DC - 26.5GHz

VSWR _____ SEE TABLE

IMPEDANCE _____ 50 OHMS

TEMPERATURE RANGE _____ 4 KELVIN TO +125°C

POWER (AVG) _____ 1 WATT
POWER DERATES LINEARLY FROM +45°C TO <10% @+125°C

POWER (PEAK) _____ 500 WATTS
(<5 μ SEC PW, <1% DUTY CYCLE)

MECHANICAL

INNER CONDUCTOR: _____ BERYLLIUM COPPER PER
ASTM B196 & B197.

OUTER CONDUCTOR: _____ STAINLESS STEEL, PER ASTM
A484 & A582, CLASS 303, COND. A.

DIELECTRIC: TEFLON PER ASTM D1710.

FINISH

INNER CONDUCTOR: _____ GOLD PLATED PER MIL-PRF-39012.

HOUSING/COUPLING NUT FINISH PER SUFFIX (REPLACING -0X IN P/N)
-00 OUTER CONDUCTOR/NUT GOLD PLATED
-02 OUTER CONDUCTOR/NUT PASSIVATED SS
-01 OUTER CONDUCTOR GOLD PLATED, NUT PASSIVATED SS

ADD "C" TO THE END OF PART NUMBER FOR CHAINED UNITS. (EXCLUDING PARTS 2001-6105-0X-CRYO AND 2001-6115-0X-CRYO)

**** EXCEPTION FOR THE 200X-6151-02-CRYO, OUTER HOUSING IS GOLD PLATED AND NUT IS PASSIVATED**

ADD C FOR 2-2.5" CHAIN ATTACHED

CONNECTOR INTERFACE COMPLIES WITH MIL-PRF-39012 AND MIL-STD-348 FOR SMA MATING CHARACTERISTICS.

RoHS COMPLIANT DEVICE

MARKING

PART LOOKS LIKE PRODUCT IMAGE ABOVE.
PART MARKING ORIENTATION AND FORMAT AS SHOWN.
MARKING TO BE AS LARGE AS POSSIBLE, CLEAR AND READABLE.
YYWW EQUALS DATE CODE.

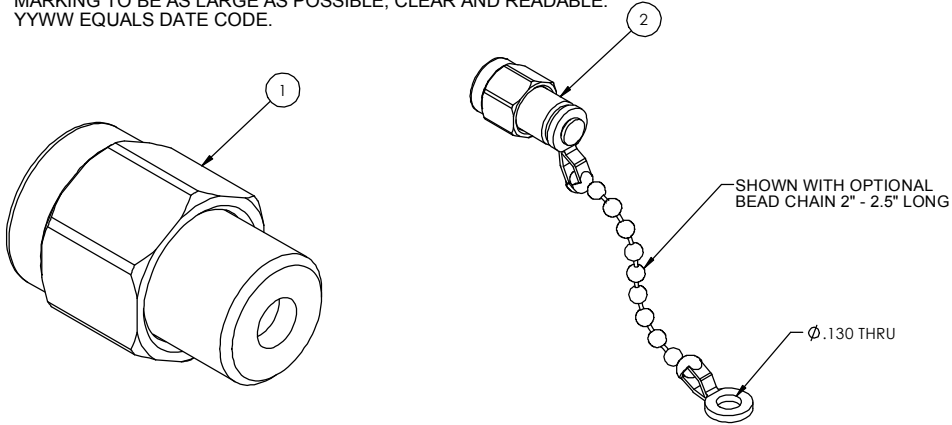

REVISIONS				
REV	DESCRIPTION	ECO #	DATE	APPROVED
C	MODIFIED TABLE; 2001-6143-0X	15-245	8/11/15	T.KUHN
D	REVISED MARKING AREA	15-297	10/7/15	T.KUHN
E	ADDED ** NOTE TO TABLE; LENGTH TOL	16-143	6/23/16	T.KUHN
F	REMOVED 2001-6118-0X	17-046	4/11/17	T.KUHN

FREQUENCY (GHz)	VSWR DC-4 (GHz)	VSWR 4-12.4 (GHz)	VSWR 12.4-18 (GHz)	VSWR 18-26.5 (GHz)	PART NUMBER
DC-4	DC-1 1.05:1 2-4 1.10:1	-	-	-	2001-6151-02-CRYO**
DC-12.4	1.05:1	1.05:1	-	-	2001-6116-0X-CRYO
DC-18	1.05:1	1.10:1	1.25:1	-	2001-6144-0X-CRYO
	1.05:1	1.15:1	1.15:1	-	2001-6105-0X-CRYO*
	1.05:1	1.15:1	1.15:1	-	2001-6100-0X-CRYO
	1.05:1	1.15:1	1.20:1	-	2001-61010X-CRYO
	1.05:1 +0.01 f (GHz)	DC - 18GHz	-	-	2001-6143-0X-CRYO
	1.05:1	1.05:1	1.10:1	-	2001-6117-0X-CRYO
	1.10:1	1.10:1	1.10:1	-	2001-6111-0X-CRYO
	1.05:1	1.15:1	1.20:1	-	2001-6112-0X-CRYO
DC-26.5	1.10:1	1.20:1	1.30:1	-	2001-6113-0X-CRYO
	1.10:1	1.20:1	1.30:1	-	2001-6115-0X-CRYO*
	1.05:1	1.10:1	1.20:1	1.30:1	2001-6110-0X-CRYO
1.05:1 + .007f (GHz) DC TO 26.5 GHz					2001-6119-0X-CRYO

*** WITH 2" TO 2.5" MONEL BEAD CHAIN**
**** EXCEPTION FOR THE 200X-6151-02-CRYO, OUTER HOUSING IS GOLD PLATED AND NUT IS PASSIVATED**

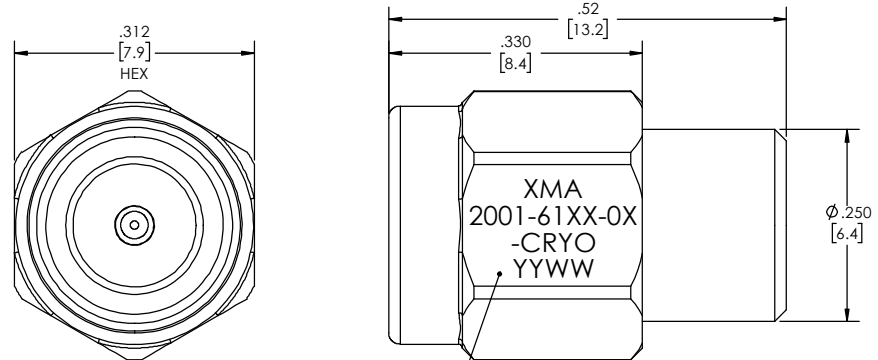

NO CHAIN	CHAIN	PART NUMBER	DESCRIPTION	ITEM NO.
		2001-61XX-0X-CRYO	TERMINATION, SMA-m, DC-26.5 GHz	
1	-	TA-2001-6000-0XYYU-CRYO	ASSEMBLY, TERMINATION, SMA-m, DC-26.5 GHz, UNMARKED	1
-	1	TA-2001-6000-0XYYUC-CRYO	ASSEMBLY, TERMINATION, SMA-m, DC-26.5 GHz, CHAINED, UNMARKED	2

DRAWING PRACTICES PER ANSI Y14.5
DIMENSIONS ARE IN INCHES AND APPLY BEFORE/AFTER PROCESSING

SURFACE ROUGHNESS: 63

FINISH: SEE NOTES

MATERIAL: REMOVE ALL BURRS/SHARP W/ BREAK / R OF .003" TO .0005"

NOTE: THIS DRAWING INCORPORATES THIRD ANGLE PROJECTION.

UNLESS OTHERWISE SPECIFIED TOLERANCES IN:
DECIMALS INCH (MM)
X" .05" [1.27]
.XX" .03" [.76]
.XXX" .010" [.25]

ANGLES ±0°30'
REMOVE ALL BURRS/SHARP W/ BREAK / R OF .003" TO .0005"
UNLESS OTHERWISE NOTED DIAS CONCENTRIC <.003 T.I.F.

DO NOT SCALE PRINT

DRAWN: MCCORMICK 11/20/11
CHECKED: MCCORMICK 11/20/11
ENG APPR: T.KUHN
DATE: 11/20/11

THESE DRAWINGS AND SPECIFICATIONS ARE THE PROPERTY OF XMA CORP. OR OMNI SPECTRA AND SHALL NOT BE REPRODUCED, COPIED NOR USED IN WHOLE OR IN PART AS A BASIS FOR THE MANUFACTURE OR SALE OF OTHER ITEMS WITHOUT THE EXPRESS WRITTEN PERMISSION OF XMA CORP.

Phone: 603-222-2256 Fax: 603-222-2259
150 Dow Street, Manchester, NH 03103

TERMINATION, SMA-m, DC-26.5 GHz

SIZE	CAGE CODE	DRAWING NUMBER	REV
C	3HT76	2001-61XX-0X-CRYO	F

SCALE: PLATED AREA 50 IN SHEET 1 OF 1

4

3

2

1