

MECHANICAL SPECIFICATIONS

MATERIALS (ALL PER MIL-PRF-39012 & MIL-DTL-39030)

- INNER CONDUCTOR: BERYLLIUM COPPER PER ASTM B196 & B197.
- OUTER CONDUCTOR: STAINLESS STEEL, CORROSION RESISTANT PER ASTM A484 & A582, CLASS 303, COND. A.
- DIELECTRIC: TEFLON PER ASTM D1710.

FINISH (ALL PER MIL-PRF-39012 & MIL-DTL-39030)

- INNER CONDUCTOR: GOLD PLATED PER MIL-PRF-39012.
- HOUSING/COUPLING NUT FINISH PER SUFFIX (REPLACING -0X IN MODEL #)
 - 00 OUTER CONDUCTOR / NUT BOTH GOLD PLATED
 - 02* OUTER CONDUCTOR / NUT BOTH PASSIVATED SS
 - 01 OUTER CONDUCTOR GOLD PLATED BUT NUT PASSIVATED SS
 - 0X-C APPENDING "-C" ADDS CHAIN ASSEMBLY, 2" - 2.5" LONG AVAILABLE ON 2001 AND 2003 SERIES

* Exception for the 200X-6151-02, Outer Is Gold Plated and Nut Is Passivated

FOR UNMARKED UNITS OR FOR CUSTOM MARKING CONTACT FACTORY FOR PART NUMBER / SUFFIX TO APPEND TO MODEL NUMBER

MEETS ALL ENVIRONMENTAL REQUIREMENTS IN MIL-DTL-39030/3

ELECTRICAL SPECIFICATIONS

Frequency Range	DC - 27 GHz (See Chart, Sht. 2)
VSWR:	SEE SHEET TWO
IMPEDANCE:	50 OHMS
TEMPERATURE RANGE (°C)	-65 TO +125 OPERATING +150° STORAGE

POWER (AVG)	1 WATT**
POWER (PEAK) (<5 m SEC PW, <1% DUTY CYCLE)	500 WATTS

**POWER DERATES LINEARLY FROM +45°C TO <10 % @+125°C

PRODUCTION RELEASE

NOTE:
THIS DRAWING INCORPORATES THIRD ANGLE PROJECTION.
INTERPRET IAW ANSI Y14.5-1995

REVISIONS		
REV	DESCRIPTION	APPROVED
-	REVISED TO NEW LAYOUT & UPDATED FORMAT	05/25/2011 D.S.S

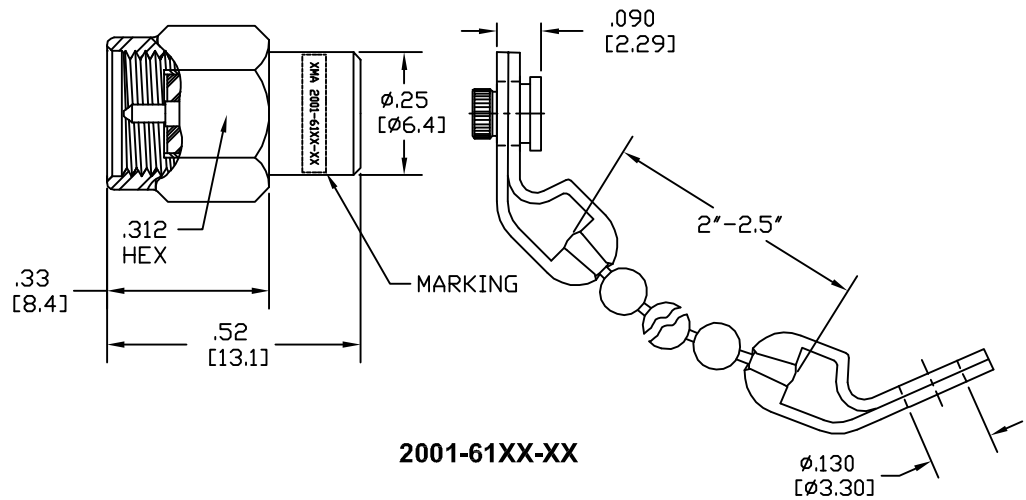

2001-61XX-XX

INTERFACES MATE / COMPLY WITH MIL-STD-348 FOR SMA

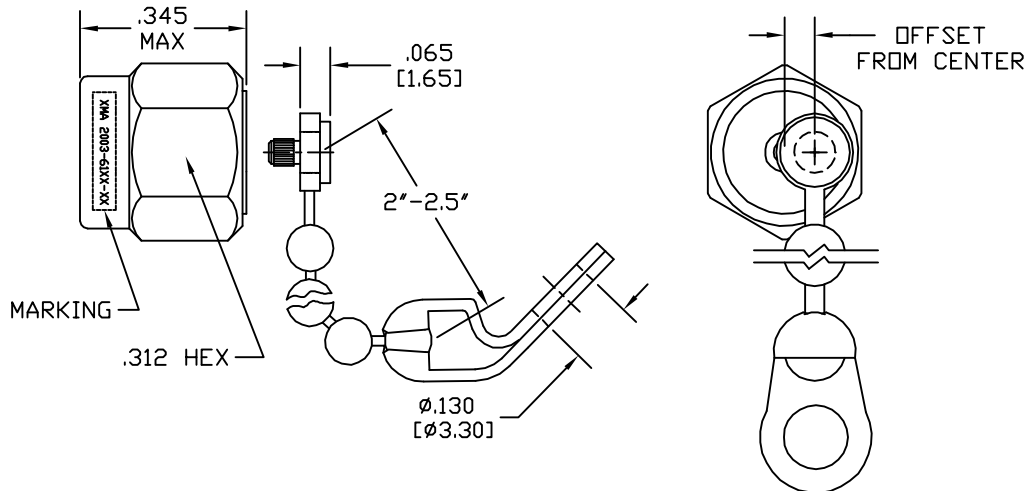

2003-61XX-XX

AVAILABLE WITH NUT WIRELOCK HOLES, CONTACT FACTORY

DRAWING PRACTICES PER ANSI Y14.5-1995 MIL-STD-100 & 1000	UNLESS OTHERWISE SPECIFIED TOLERANCES IN DECIMALS INCH MM .XX .05" [1.3] .XXX .030" [.76] .XXXX .015 [.39] .XXXXX .0005" [.013]	DATE DRAWN T. MAIN 05/16/2011 CHECKED D. SAUNDERS 05/25/2011 DATE D. SAUNDERS 05/25/2011
DIMENSIONS ARE IN INCHES AND APPLY BEFORE/AFTER PROCESSING	ANGLES ±	THESE DRAWINGS AND SPECIFICATIONS ARE THE PROPERTY OF XMA CORP. / OMNISPECTRA AND SHALL NOT BE REPRODUCED, COPIED, NOR USED, IN WHOLE OR IN PART, AS A BASIS FOR THE DESIGN, MANUFACTURE OR SALE OF OTHER ITEMS WITHOUT THE EXPRESS WRITTEN PERMISSION OF XMA CORP., CUSTOMERS AND VENDORS MAY COPY FOR INTERNAL REVIEW USE AS WEDED
SURFACE FINISH	UNLESS OTHERWISE NOTED DIAS CONCENTRIC <.003 T.I.R.	SCALE 5 1 1
FINISH SEE NOTES		PLATE OFF CO. REF. B.C.H.F.
MATERIALS SEE NOTES		SHEET 1 OF 2

WWW.XMACORP.COM Sales@XMACORP.COM



XMA Corp. 150 Dow St. Manchester, NH 03045 (603) 222-2256 fax 222-2259

TITLE
1 WATT SMA TERMINATION
DC TO 27 GHz

SIZE C	CAGE CODE 3HT76	DWG NO. 2001-61XX-XX
--------	-----------------	----------------------

REVISIONS		
REV	DESCRIPTION	APPROVED
-	REVISED TO NEW LAYOUT & UPDATED FORMAT	05/25/2011 D.S.S

FREQUENCY (GHz)	AVERAGE POWER (WATTS)	VSWR DC - 4 (GHz)	VSWR 4 - 12.4 (GHz)	VSWR 12.4 - 18 (GHz)	VSWR 18 - 26.5 (GHz)	PART NUMBER
DC - 4.0	1.0	DC-2 1.10:1	-	-	-	2001-6500-0X
		2-4 1.15:1	-	-	-	2001-6501-0X
		DC-1 1.05:1	-	-	-	2001-6151-02
		2-4 1.10:1	-	-	-	2003-6151-02
DC - 12.4	1.0	1.05:1	1.05:1	-	-	2001-6116-0X
		1.05:1	1.05:1	-	-	2003-6116-0X
DC - 18.0	1.0	1.05:1	1.15:1	1.15:1	-	2001-6105-0X
		1.05:1	1.15:1	1.15:1	-	2001-6100-0X
		1.05:1	1.15:1	1.20:1	-	2001-6101-0X
		1.09:1	1.17:1	1.23:1	-	2001-6143-0X
		1.05:1	1.05:1	1.05:1	-	2001-6118-0X
		1.05:1	1.05:1	1.10:1	-	2001-6117-0X
		1.10:1	1.10:1	1.10:1	-	2001-6111-0X
		1.05:1	1.15:1	1.20:1	-	2001-6112-0X
		1.10:1	1.20:1	1.30:1	-	2001-6113-0X
		1.10:1	1.20:1	1.30:1	-	2001-6115-0X
		1.05:1	1.05:1	1.10:1	-	2003-6117-0X
		1.10:1	1.10:1	1.10:1	-	2003-6111-0X
		1.05:1	1.15:1	1.20:1	-	2003-6112-0X
		1.10:1	1.20:1	1.30:1	-	2003-6113-0X
1.10:1	1.20:1	1.30:1	-	2003-6115-0X		
DC - 26.5	1.0	1.05:1	1.10:1	1.20:1	1.30:1	2001-6110-0X
		1.05:1	1.10:1	1.20:1	1.30:1	2003-6110-0X
		1.05:1 + .007f (GHz) 1.05 @ DC to 1.24 @ 26.5 GHz				

 Powered by: 

XMA Corp. 150 Dow St. Manchester, NH 03045 (603) 222-2256 fax 222-2259

TITLE
 1 WATT SMA TERMINATION
 DC TO 27 GHz

SIZE C	CAGE CODE 3HT76	DWG NO. 2001-61XX-XX
SCALE 5 : 1	PLATE OFF EQ. REF. RCHFS	XXX SHEET 2 OF 2